

HIGH PERFORMANCE AIR COOLED UV LED SYSTEM



Phoseon Technology UV LED light systems deliver superior performance, maximum UV energy and real-world reliability in both air and water cooled configurations. Ultraviolet (UV) LED systems are compact solid-state devices providing low energy consumption without moving parts. They are environmentally friendly with no ozone generation and mercury free. Phoseon's patented Semiconductor Light Matrix (SLM)TM Technology provides the following features and benefits:



FEATURES

Performance: High Intensity Light Source
Semiconductor Light Matrix (SLM) TM Technology
Reliability: consistent UV output over time, longer life
Instant on/off - Enabled only when required for curing
Environmentally Friendly
Small form factor and integrated electronic controls
Cooler operating temperature

BENEFITS

Spectral radiant power equivalent to multi kilowatt mercury vapor lamp
Increased productivity, maintenance free
Lower cost of ownership
Less energy required, lower operating costs
Safer - mercury and ozone free
Easy Integration
Ability to cure on heat sensitive substrates

APPLICATIONS

Phoseon products are successfully curing inks, coatings and adhesives in many demanding applications today. Here are a few examples:

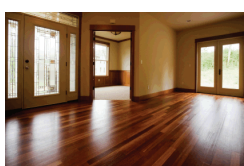

StarFire Datasheet

SPECIFICATIONS

Emitting Window	Product	Dimensions	Product Family Features
100 x 20mm 150 x 20mm		254 x 48 x 144mm 0.9 kg (2 lbs)	 Air Cooled *Peak Irradiance: 2W/cm ² Total UV Power: Up to 60W Pure UV Output: 380-420nm Interface Control: PLC Safety: CE, RoHS and REACH Compliant

*Peak Irradiance (the maximum measured irradiance at the output of the UV emitting window)
 All standard products have a peak wavelength of 395nm

UV LED VS MERCURY SPECTRAL DISTRIBUTION

UV LED curing lamps efficiently convert 15-30% of the input electrical power into usable UV light with no harmful UV-C or infrared exposure. That efficiency translates into approximately 80% power and heat savings over mercury based lamps.

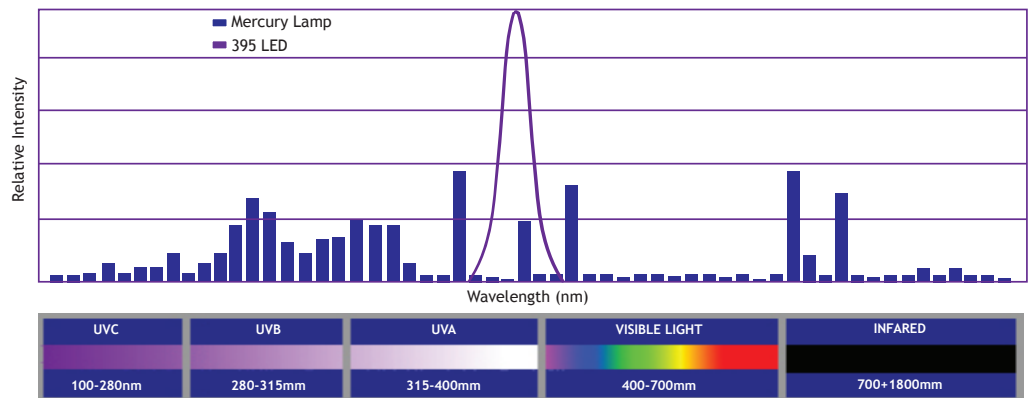

Interested in integrating our technology? Phoseon can tailor a solution for your particular integration needs. Please contact us to discuss your specific requirements.



www.phoseon.com
info@phoseon.com